

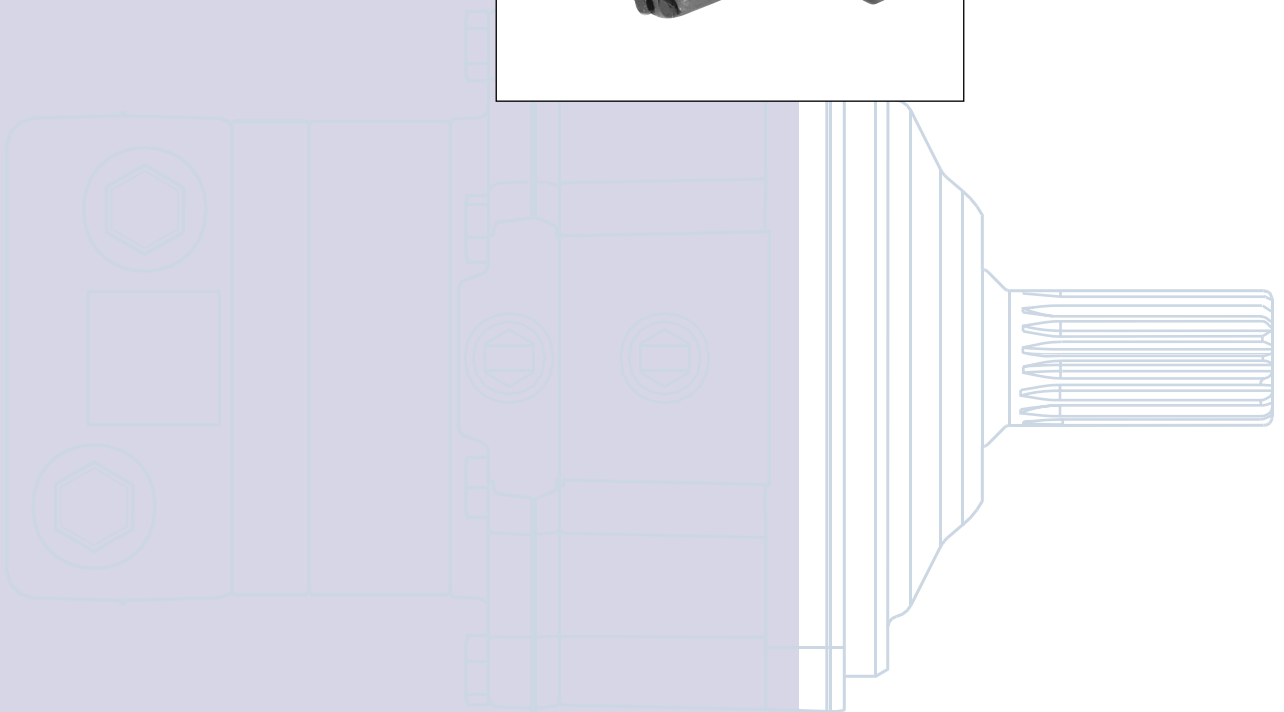

TMT, TMTU, TMTW, TMT FL and TMTW FL Orbital Motors

Technical Information

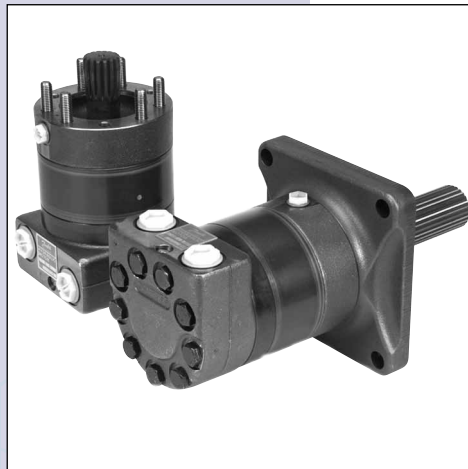
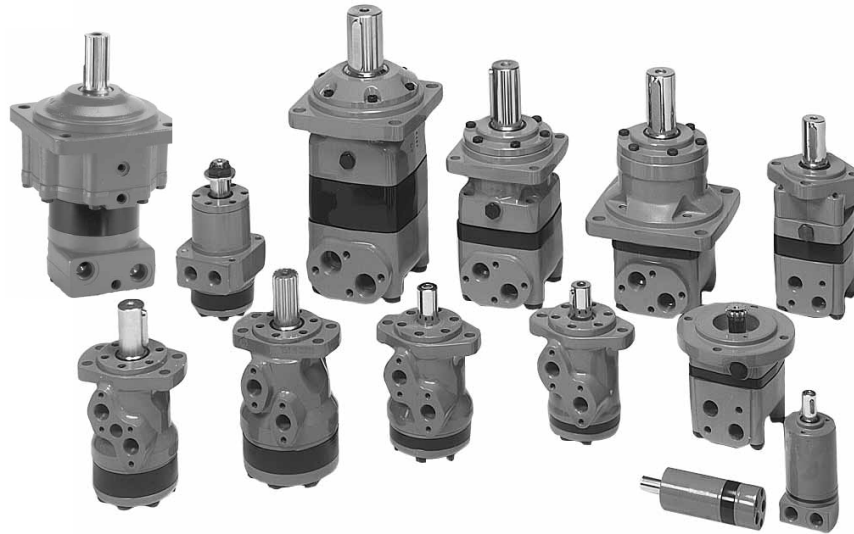

**A Wide Range of
Orbital Motors**

F300030 Tif

Sauer-Danfoss is a world leader within production of low speed orbital motors with high torque. We can offer more than 1600 different orbital motors, categorised in types, variants and sizes (incl. different shaft versions).

The motors vary in size (rated displacement) from 8 cm³ [0.50 in³] to 800 cm³ [48.9 in³] per revolution.

Speeds range up to approx. 2500 min⁻¹ (rpm) for the smallest type and up to approx. 600 min⁻¹ (rpm) for the largest type.

Maximum operating torques vary from 13 N•m [115 lbf•in] to 2700 N•m [24.000 lbf•in] (peak) and maximum outputs are from 2,0 kW [2,7 hp] to 70 kW [95 hp].

Characteristic features:

- Smooth running over the entire speed range
- Constant operating torque over a wide speed range
- High starting torque
- High return pressure without the use of drain line (High pressure shaft seal)
- High efficiency
- Long life under extreme operating conditions
- Robust and compact design
- High radial and axial bearing capacity
- For applications in both open and closed loop hydraulic systems
- Suitable for a wide variety of hydraulics fluids

© 2010 Sauer-Danfoss. All rights reserved. Printed in Europa
Sauer-Danfoss accepts no responsibility for possible errors in catalogs, brochures and other printed material. Sauer-Danfoss reserves the right to alter its products without prior notice. This also applies to products already ordered provided that such alterations aren't in conflict with agreed specifications. All trademarks in this material are properties of their respective owners. Sauer-Danfoss and the Sauer-Danfoss logotype are trademarks of the Sauer-Danfoss Group.

Front page: F300 286, F300 540, F300 281, F300 282, F300731, :151-1944

**A Wide Range of
Orbital Motors
(continued)**

The programme is characterised by technical features appealing to a large number of applications and a part of the programme is characterised by motors that can be adapted to a given application. Adaptions comprise the following variants among others:

- Motors with corrosion resistant parts
- Wheel motors with recessed mounting flange
- OMP, OMR- motors with needle bearing
- OMR motor in low leakage version
- OMR motors in a super low leakage version
- Short motors without bearings
- Ultra short motors
- Motors with integrated positive holding brake
- Motors with integrated negative holding brake
- Motors with integrated flushing valve
- Motors with speed sensor
- Motors with tacho connection
- All motors are available with black finish paint

The Sauer-Danfoss orbital motors are used in the following application areas:

- Construction equipment
- Agricultural equipment
- Material handling & Lifting equipment
- Forestry equipment
- Lawn and turf equipment
- Special purpose
- Machine tools and stationary equipment
- Marine equipment

**Survey of Literature with
Technical Data on
Sauer-Danfoss
Orbital Motors**

Detailed data on all Sauer-Danfoss motors can be found in our motor catalogue, which is divided into 5 individual subcatalogues:

- General information on Sauer-Danfoss orbital motors: function, use, selection of hydraulic motor, hydraulic systems, etc.
- Technical data on small motors: OML and OMM
- Technical data on medium sized motors: OMP, OMR, OMH and OMEW
- Technical data on medium sized motors: DH and DS
- Technical data on large motors: OMS, OMT and OMV
- Technical data on large motors: TMT

A general survey brochure on Sauer-Danfoss orbital motors gives a quick motor reference based on power, torque, speed and capabilities.

Contents	Speed and torque	5
Versions	Versions	6
Code Numbers	Code numbers.....	7
Technical Data	Technical data.....	8
	Technical data (e.g. speed, torque, pressure etc.).....	8
	Max. permissible shaft seal pressure	9
	Pressure drop in motor, oil flow in drain line, direction of shaft rotation.....	10
	Permissible shaft load	11
	Function diagrams.....	15
	Shaft Versions.....	18
	Port thread versions.....	20
Dimensions	Dimensions	21
Weight	Weight	35

Speed and Torque

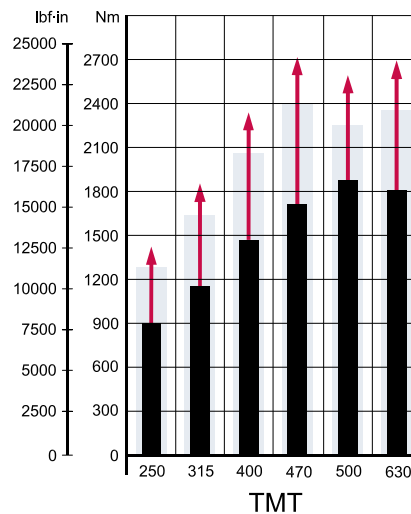
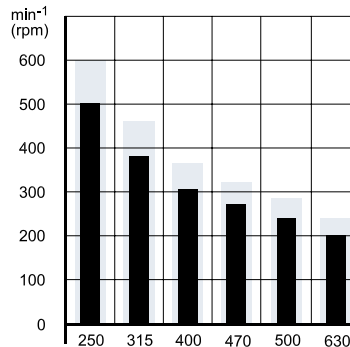

The bar diagrams above are useful for a quick selection of relevant motor size for the application. The final motor size can be determined by using the function diagram for each motor size.

- *TMT can be found* on pages 15 - 17.

The function diagrams are based on actual tests on a representative number of motors from our production. The diagrams apply to a return pressure between 5 and 10 bar [75 and 150 psi] when using mineral based hydraulic oil with a viscosity of 35 mm²/s [165 SUS] and a temperature of 50°C [120°F]. For further explanation concerning how to read and use the function diagrams, please consult the paragraph "Selection of motor size" in the technical information "General" DHMH.PK.100.G2.02 520L0232.

Versions

Mounting flange	Spigot diameter	Bolt circle diameter (BC)	Shaft	Port size	European version	US version	Side port version	Standard shaft seal	Drain connection	Check valve	Main type designation
4-Bolt	Ø 160 mm	Ø 200 mm	Cyl 40 mm	G 3/4	☺		☺	☺	yes	No	TMT
	Ø 125 mm	Ø 160 mm	Cyl 40 mm	G 3/4	☺		☺	☺	Yes	No	TMT
	Ø 5 in	Ø 6.37 in	Cyl 1.5 in	1 1/16 - 12 UN		☺	☺	☺	Yes	No	TMT
	Ø 160 mm	Ø 200 mm	Splined 1.5 in	G 3/4	☺		☺	☺	Yes	No	TMT
	Ø 125 mm	Ø 160 mm	Splined 1.5 in	G 3/4	☺		☺	☺	yes	No	TMT
	Ø 5 in	Ø 6.37 in	Splined 1.5 in	1 1/16 - 12 UN		☺	☺	☺	Yes	No	TMT
	Ø 160 mm	Ø 200 mm	Tap. 45 mm	G 3/4	☺		☺	☺	Yes	No	TMT
	Ø 125 mm	Ø 160 mm	Tap. 45 mm	G 3/4	☺		☺	☺	yes	No	TMT
	Ø 5 in	Ø 6.37 in	Tap. 1 3/4 in	1 1/16 - 12 UN		☺	☺	☺	Yes	No	TMT
	-	-	-	G 3/4	☺		☺		Yes	No	TMT U
-	-	-	1 1/16 - 12 UN		☺	☺		Yes	No	TMT U	
4-Bolt	Ø 125 mm	Ø 160 mm	Splined 1.5 in	G 3/4	☺		☺	☺	Yes	No	TMT FL
	Ø 5 in	Ø 6.37 in	Splined 1.5 in	1 1/16 - 12 UN		☺	☺	☺	Yes	No	TMT FL
	Ø 180 mm	Ø 224 mm	Splined 1.5 in	G 3/4	☺		☺	☺	Yes	No	TMT FL
	Ø 180 mm	Ø 224 mm	Tap. 45 mm	G 3/4	☺		☺	☺	Yes	No	TMT FL
	Ø 7.08 in	Ø 8.82 in	Splined 1.5 in	1 1/16 - 12 UN		☺	☺	☺	Yes	No	TMT FL
Wheel	Ø 180 mm	Ø 210 mm	Thread hole fl.	G 3/4	☺		☺	☺	Yes	No	TMTW
	Ø 180 mm	Ø 210 mm	Thread hole fl.	1 1/16 - 12 UN		☺	☺	☺	Yes	No	TMTW
	Ø 160 mm	Ø 194 mm	Tap. 45 mm	1 1/16 - 12 UN		☺	☺	☺	Yes	No	TMTW FL

Function diagram – see page : →

Features available (options)

- Flushing valve with different flushing flow
- Brake with higher holding torque capacity
- Painted

Code Numbers

DISPLACEMENT [cm ³]						Technical data – Page	Dimensions – Page
250	315	400	470	500	630		
151Z3010	151Z3011	151Z3012	151Z3013	151Z3014	151Z3015	8	23
151Z3016	151Z3017	151Z3018	-	-	-	8	24
151Z3060	151Z3061	151Z3062	151Z3063	151Z3064	151Z3065	8	25
151Z3020	151Z3021	151Z3022	151Z3023	151Z3024	151Z3025	8	23
151Z3026	151Z3027	151Z3028	-	-	-	8	24
151Z3070	151Z3071	151Z3072	151Z3073	151Z3074	151Z3075	8	25
151Z3030	151Z3031	151Z3032	151Z3033	151Z3034	151Z3035	8	23
151Z3036	151Z3037	151Z3038	-	-	-	8	24
151Z3080	151Z3081	151Z3082	151Z3083	151Z3084	151Z3085	8	25
151Z3000	151Z3001	151Z3002	151Z3003	151Z3004	151Z3005	8	26
151Z3100	151Z3101	151Z3102	151Z3103	151Z3104	151Z3105	8	27
151Z3040	151Z3041	151Z3042	151Z3043	151Z3044	151Z3045	8	28
151Z3050	151Z3051	151Z3052	151Z3053	151Z3054	151Z3055	8	28
151Z3090	151Z3091	151Z3092	151Z3093	151Z3094	151Z3095	8	29
151Z3110	151Z3111	151Z3112	151Z3113	151Z3114	151Z3115	8	31
151Z3120	151Z3121	151Z3122	151Z3123	151Z3124	151Z3125	8	31
151Z3130	151Z3131	151Z3132	151Z3133	151Z3134	151Z3135	8	30
151Z3229	151Z3230	151Z3231	151Z3232	151Z3233	151Z3234	8	32
151Z3273	151Z3274	151Z3275	151Z3276	151Z3277	151Z3278	8	33
11033922	11033923	11033924		11033926	11033927	8	34
15	15	16	16	17	17		

Technical data for TMT, TMTU, TMTW and TMT FL

Type			TMT 250	TMT 315	TMT 400	TMT 470	TMT 500	TMT 630
Geometric displacement	cm ³ [in ³]		251.8 [15.37]	326.3 [19.91]	410.9 [25.07]	477.3 [29.13]	494.8 [30.19]	629.1 [38.39]
Max. speed	min ⁻¹ [rpm]	cont.	500	380	305	270	250	200
		int. ¹⁾	600	460	360	320	300	240
Max. torque	N·m [lbf·in]	cont.	940 [8320]	1230 [10890]	1520 [13450]	1760 [15580]	1770 [15670]	1830 [16200]
		int. ¹⁾	1290 [11420]	1660 [14690]	2120 [18760]	2420 [21420]	2240 [19825]	2290 [20270]
		peak ²⁾	1440 [12 745]	1865 [16 500]	2355 [20 845]	2735 [24 210]	2390 [21150]	2740 [24250]
Max. output	kW [hp]	cont.	35 [47]	35 [47]	37 [50]	37 [50]	35 [47]	27 [36]
		int. ¹⁾	47 [63]	47 [63]	51 [68]	49 [66]	42 [56]	33 [44]
Max. pressure drop	bar [psi]	cont.	250 [3630]	250 [3630]	250 [3630]	250 [3630]	250 [3630]	200 [2900]
		int. ¹⁾	350 [5080]	350 [5080]	350 [5080]	350 [5080]	325 [4710]	250 [3630]
		peak ²⁾	400 [5800]	400 [5800]	400 [5800]	400 [5800]	375 [5440]	300 [4350]
Max. oil flow	l/min [USgal/min]	cont.	125 [33]	125 [33]	125 [33]	125 [33]	125 [33]	125 [33]
		int.1)	150 [39.6]	150 [39.6]	150 [39.6]	150 [39.6]	150 [39.6]	150 [39.6]
Max. starting pressure with unloaded shaft	bar [psi]		6 [90]	6 [90]	6 [90]	6 [90]	6 [90]	6 [90]
Min. starting torque	at max. press. drop	cont.	780 [6690]	1060 [9380]	1360 [12040]	1500 [13280]	1530 [13 540]	1600 [14160]
	N·m [lbf·in]							
	at max. press. drop int.1)		1080 [9560]	1520 [13450]	1930 [17080]	2050 [18140]	1820 [16100]	1980 [17500]
N·m [lbf·in]								

Type		Max. inlet pressure	Max. return pressure with drain line
TMT 250 - 630	bar cont.	270	140
	[psi]	[3915]	[2030]
	bar int.1)	370	175
	[psi]	[5365]	[2540]
	bar peak2)	420	210
	[psi]	[6090]	[3045]

For max. permissible combination of flow and pressure, see function diagram for actual motor

¹⁾ Intermittent operation: the permissible values may occur for max. 10% of every minute

²⁾ Peak load: the permissible value may occur for max. 1% of every minute

Technical data for brake motor TMT fl and TMTW FL

Technical data for brake motor TMT FL and TMTW FL		
Holding torque ¹⁾	N·m [lbf·in]	2000 [17 700]
Min. release pressure ²⁾	bar [psi]	13 [190]
Max. release pressure cont.	bar [psi]	20 [365]
Max. release pressure peak	bar [psi]	40 [580]

¹⁾ Brakes with higher holding torque available, please contact Sauer-Danfoss.

²⁾ The release pressure is the difference between the pressure in the brake line and the pressure in the drain line.

Bleed off from brake release chamber to drain line is 0.65 l/min [0.172 US gal/min] at 13 bar [188 psi] release pressure.

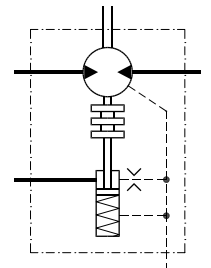

151-1931.10

Max. Permissible Shaft Seal Pressure

TMT with standard shaft seal and drain connection.
 The pressure on shaft seal equals the pressure in the drain line.

TMT FL and TMTW FL with standard shaft seal.
 The pressure on shaft seal equals the pressure in release port.

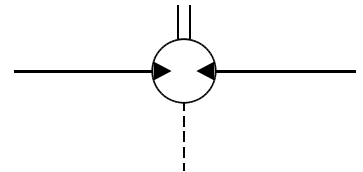

151-1983.10

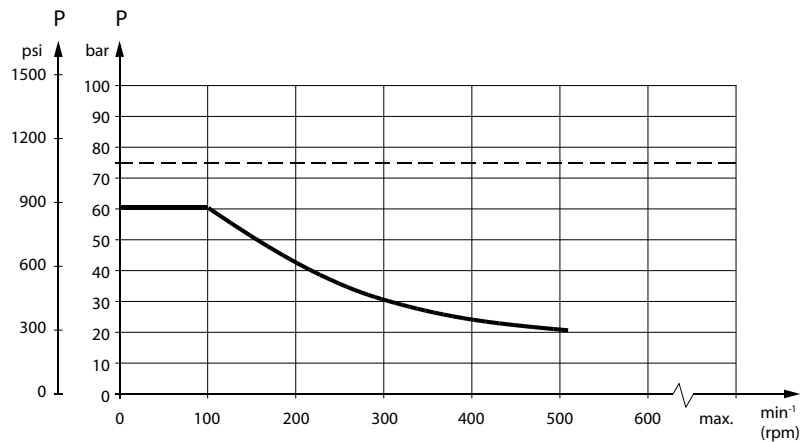

151-1673.10

--- Intermittent operation: The permissible values may occur for max. 10% of every minute.

— Continuous operation

Warning

Drain line should always be used.

Pressure Drop in Motor

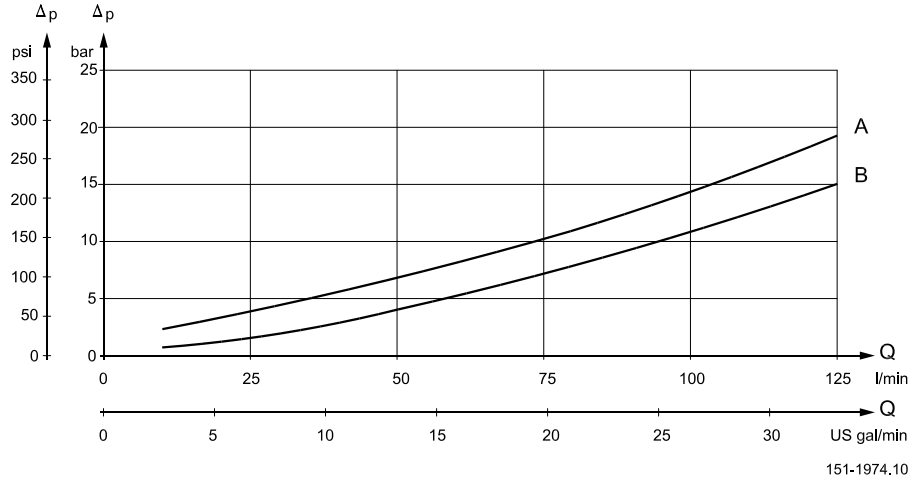

The curve applies to an unloaded motor shaft and an oil viscosity of 35 mm²/s [165 SUS].
 A: TMT 250, 315 B: TMT 400, 470, 500 and 630

Oil Flow in Drain Line

The table below shows the max. oil flow in the drain line at a return pressure less than 5-10 bar [75-150 psi].

Pressure drop bar [psi]	Viscosity	Oil flow in drain line
	mm ² /s [SUS]	l/min [US gal/min]
200 [2900]	20 [100]	2.5 [0.66]
	35 [165]	1.5 [0.4]
275 [3990]	20 [100]	4.0 [1.1]
	35 [165]	2.5 [0.66]

Direction of Shaft Rotation

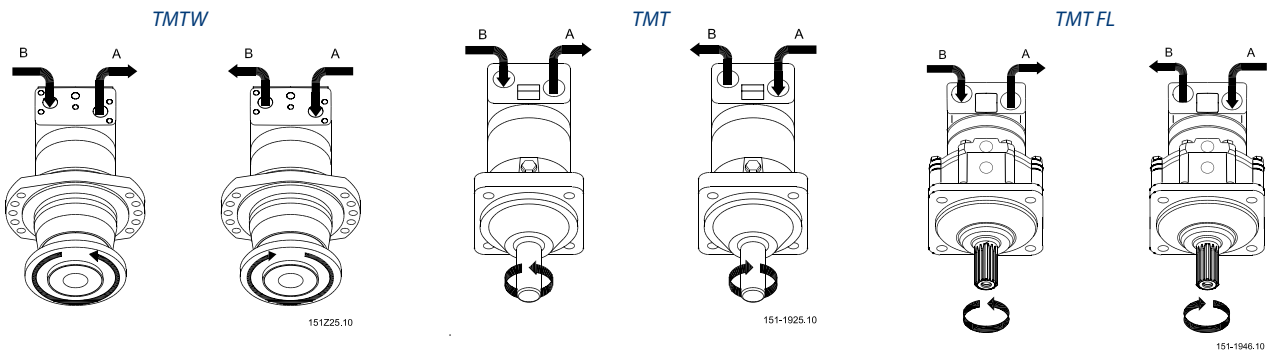

**Permissible Shaft Load
 for TMT and TMT FL**

Spigot diameter $\varnothing 160$ mm [6.3 in] TMT and $\varnothing 180$ mm [7.1 in] TMT FL

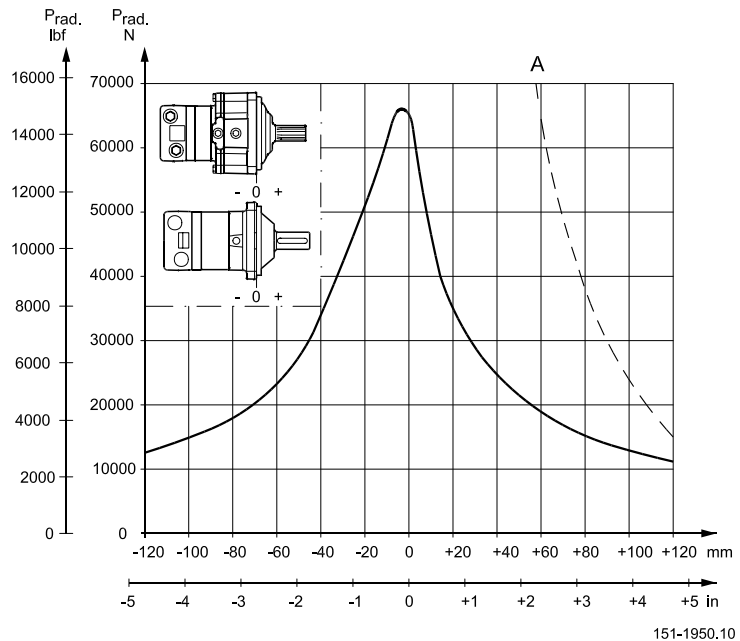

Permissible radial shaft load

The output shaft runs in tapered roller bearings that permit high axial and radial forces.

The permissible radial load on the shaft is shown for an axial load of 0 N as a function of the distance from the mounting flange to the point of load application.

The curve is based on B_{10} Bearing life (2000 hours or 12 000 000 shaft revolutions at 100 min^{-1}) at rated output torque, when mineral-based hydraulic oil with a sufficient content of anti-wear additives, is used.

The dash curve **A** shows max. radial shaft load. Any shaft load exceeding the values shown in the curve will involve a risk of breakage.

**Permissible Shaft Load
 for TMT and TMT FL
 (continued)**

Spigot diameter \varnothing 125 mm [4.92 in] TMT and TMT FL

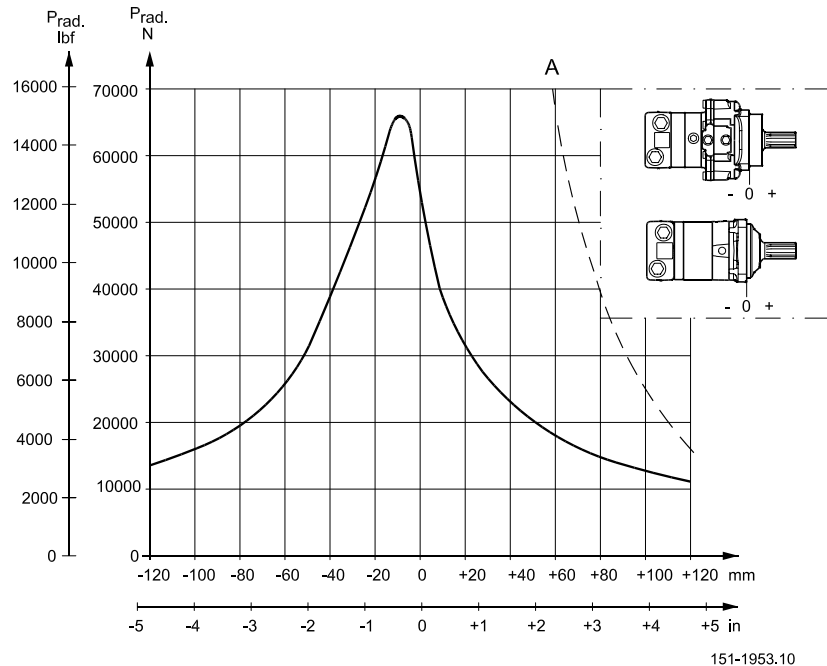

Permissible radial shaft load

The output shaft runs in tapered roller bearings that permit high axial and radial forces.

The permissible radial load on the shaft is shown for an axial load of 0 N as a function of the distance from the mounting flange to the point of load application.

The curve is based on B_{10} Bearing life (2000 hours or 12 000 000 shaft revolutions at 100 min^{-1}) at rated output torque, when mineral-based hydraulic oil with a sufficient content of anti-wear additives, is used.

The dash curve **A** shows max. radial shaft load. Any shaft load exceeding the values shown in the curve will involve a risk of breakage.

**Permissible Shaft Load
 for TMT and TMT FL
 (continued)**

Spigot diameter \varnothing 127 mm [5.0 in] TMT and TMT FL

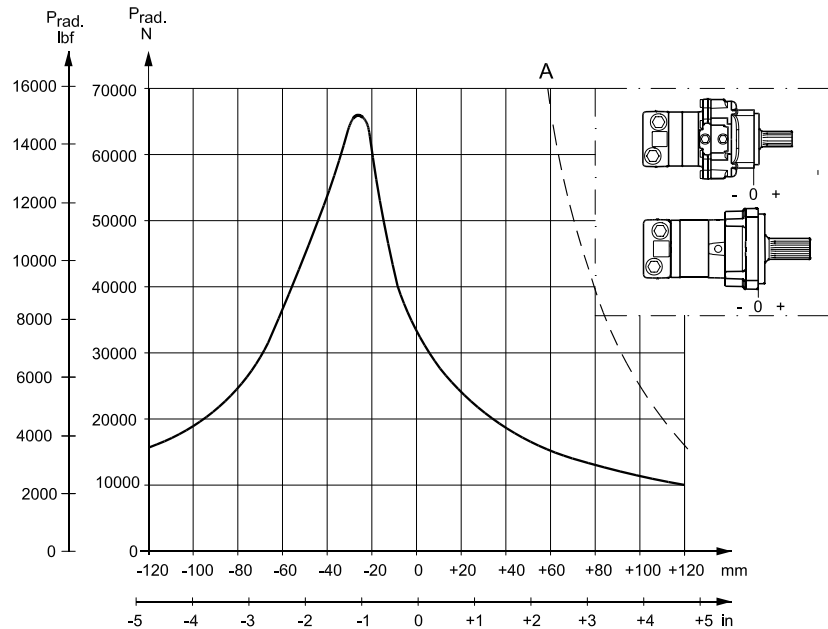

151-1952.10

Permissible radial shaft load

The output shaft runs in tapered roller bearings that permit high axial and radial forces.

The permissible radial load on the shaft is shown for an axial load of 0 N as a function of the distance from the mounting flange to the point of load application.

The curve is based on B_{10} Bearing life (2000 hours or 12 000 000 shaft revolutions at 100 min^{-1}) at rated output torque, when mineral-based hydraulic oil with a sufficient content of anti-wear additives, is used.

The dash curve **A** shows max. radial shaft load. Any shaft load exceeding the values shown in the curve will involve a risk of breakage.

**Permissible Shaft Load
 for TMTW**

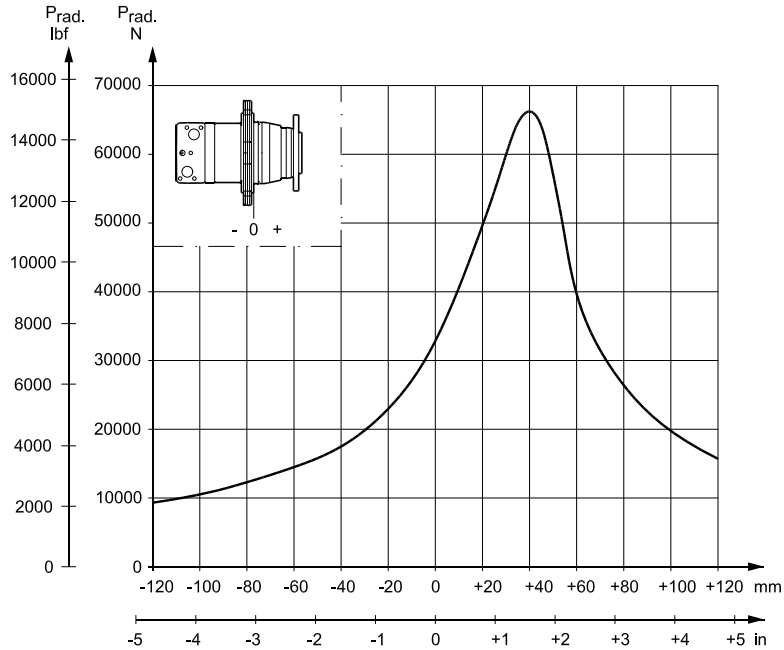

151Z22.10

**Permissible Shaft Load
 for TMTW FL**

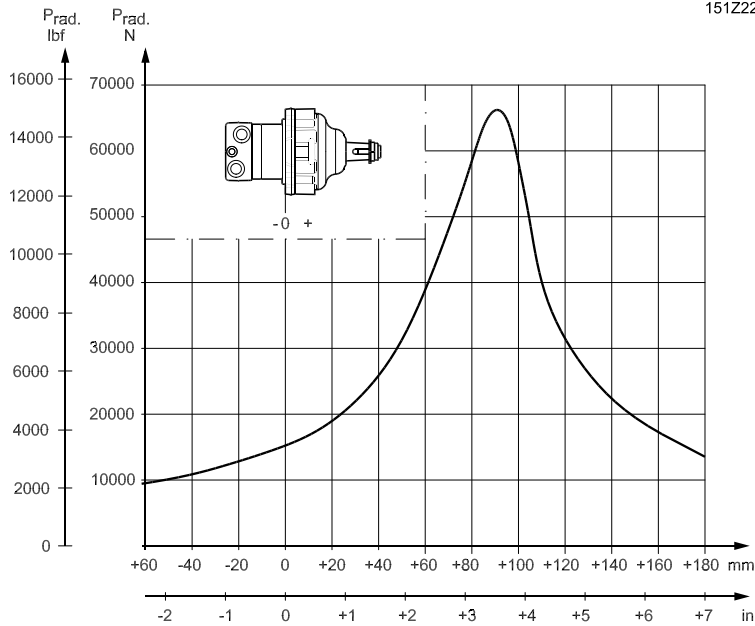

151Z45.10

Permissible radial shaft load

The output shaft runs in tapered roller bearings that permit high axial and radial forces.

The permissible radial load on the shaft is shown for an axial load of 0 N as a function of the distance from the mounting flange to the point of load application.

The curve is based on B_{10} Bearing life (2000 hours or 12 000 000 shaft revolutions at 100 min^{-1}) at rated output torque, when mineral-based hydraulic oil with a sufficient content of anti-wear additives, is used.

Function Diagrams

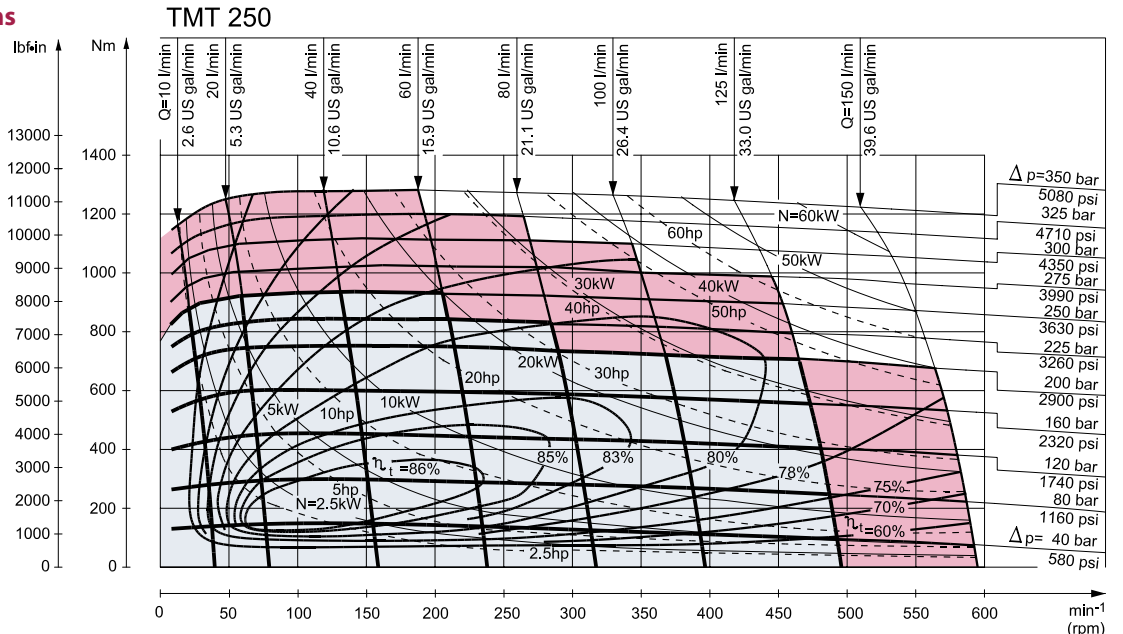

151-1988.11

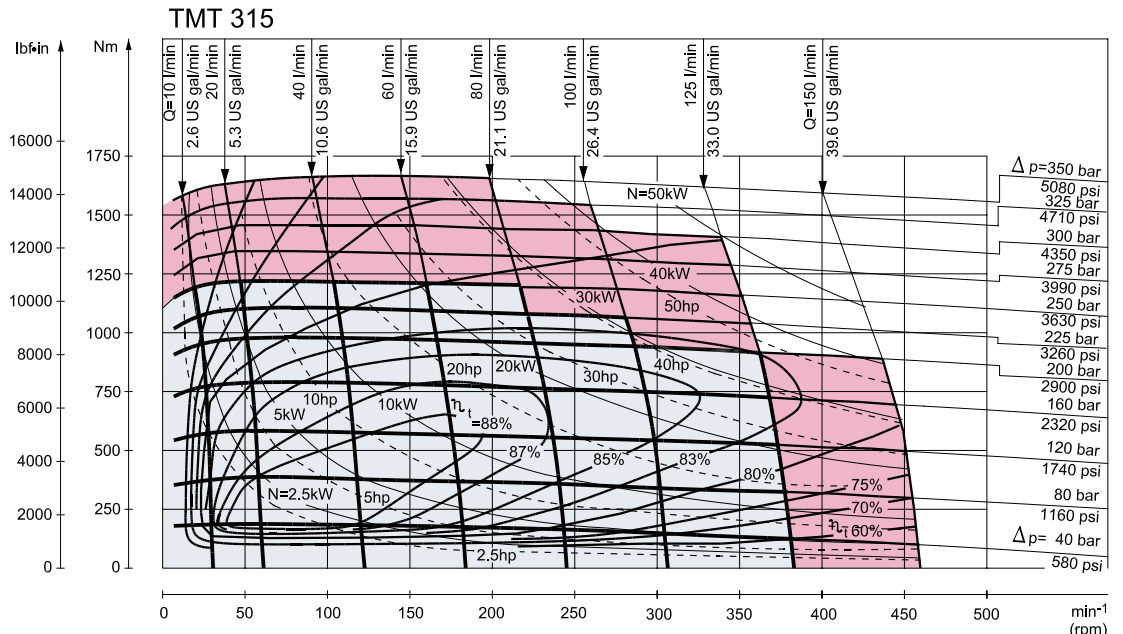

151-1989.11

Explanation of function diagram use, *basis and conditions* can be found on page 5.

- Continuous range
- Intermittent range (max. 10% operation every minute)

Intermittent pressure drop and oil flow must not occur simultaneously.

Function Diagrams
 (continued)

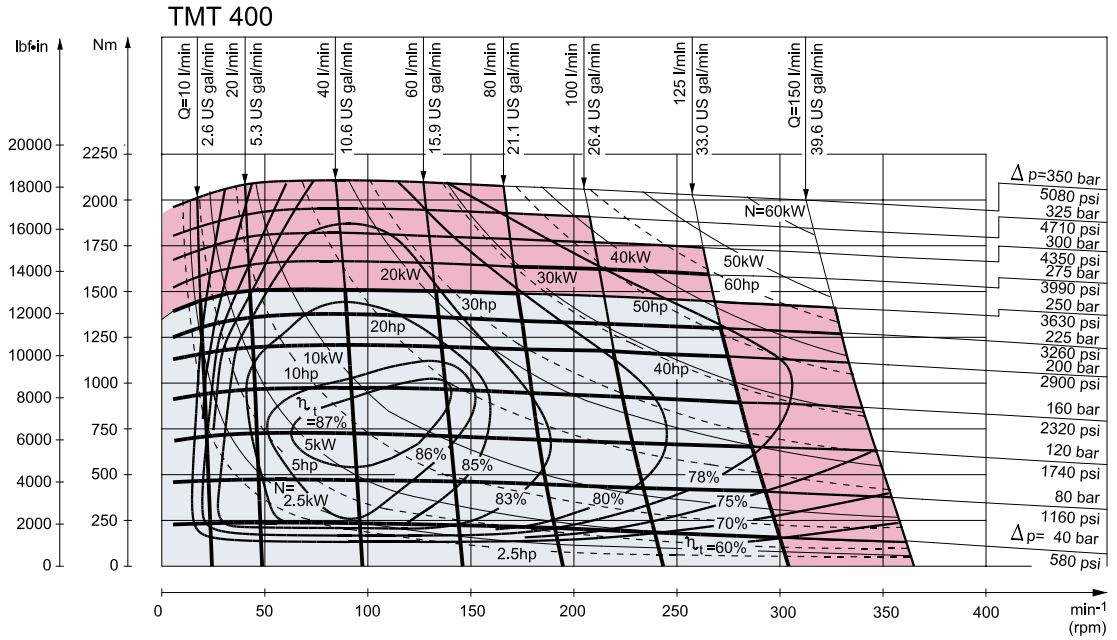

151-1987.11

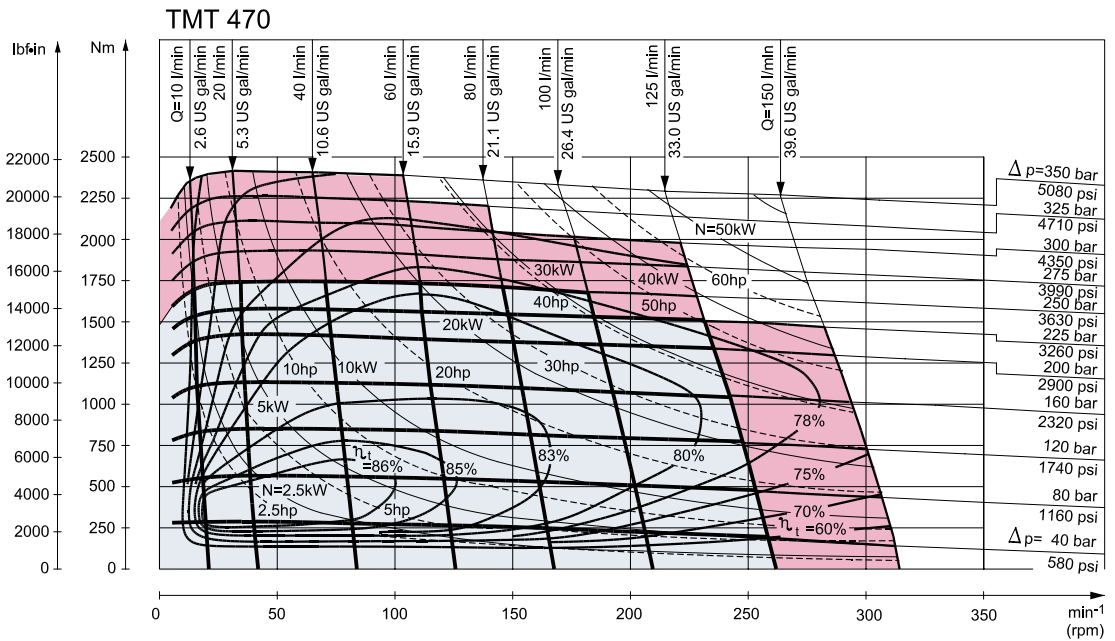

151-1986.12

Explanation of function diagram use, *basis and conditions* can be found on page 5.

- Continuous range
- Intermittent range (max. 10% operation every minute)

Intermittent pressure drop and oil flow must not occur simultaneously.

Function Diagrams
 (continued)

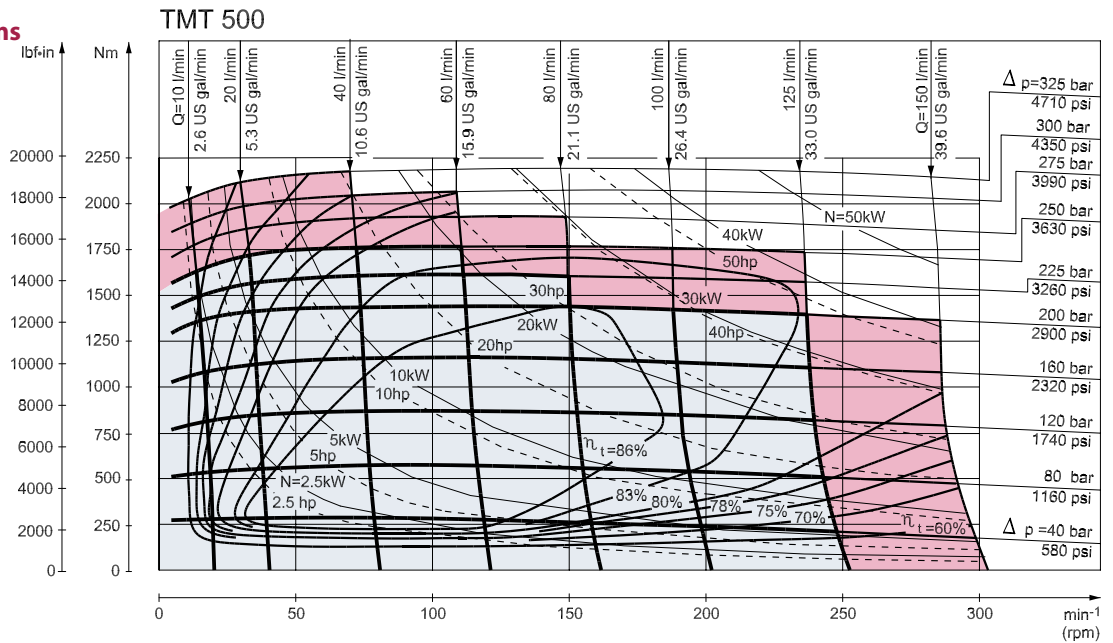

151-2019.12

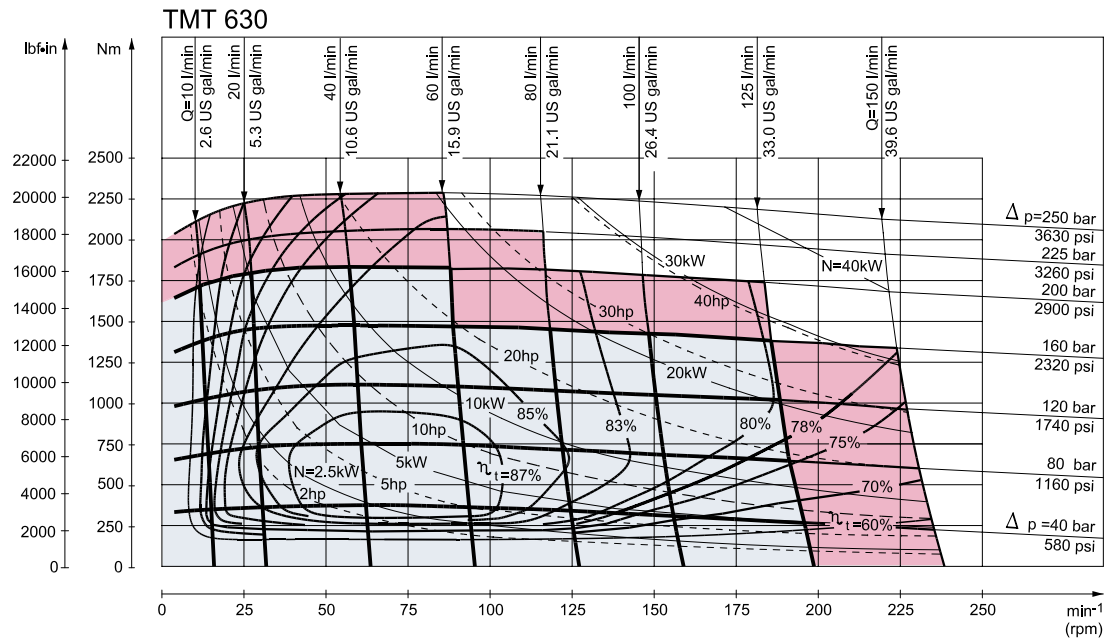

151-2020.10

Explanation of function diagram use, *basis and conditions* can be found on page 5.

- Continuous range
- Intermittent range (max. 10% operation every minute)

Intermittent pressure drop and oil flow must not occur simultaneously.

Shaft Versions

- A: Cylindrical shaft $\varnothing 40$ mm
- F: Parallel key
 A12 x 8 x 70
 DIN 6885

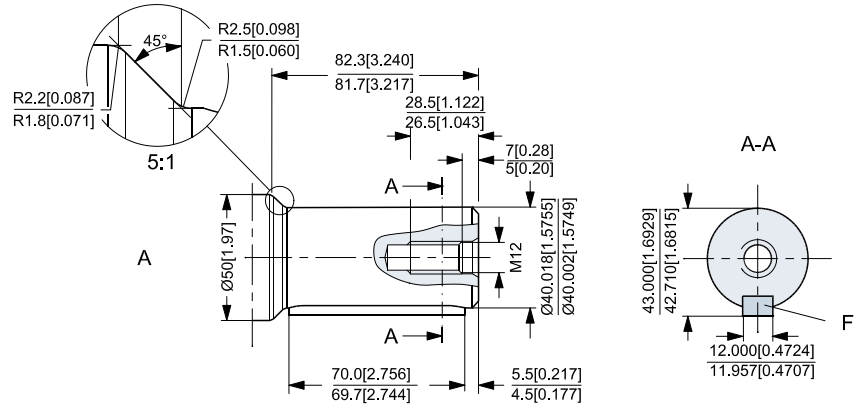

- B: Involute splined shaft ANS
 B92.1 - 1970 standard
 Flat root side fit
 Pitch 12/24
 Teeth 17
 Major diam. 1.50 inch
 Pressure angle 30°

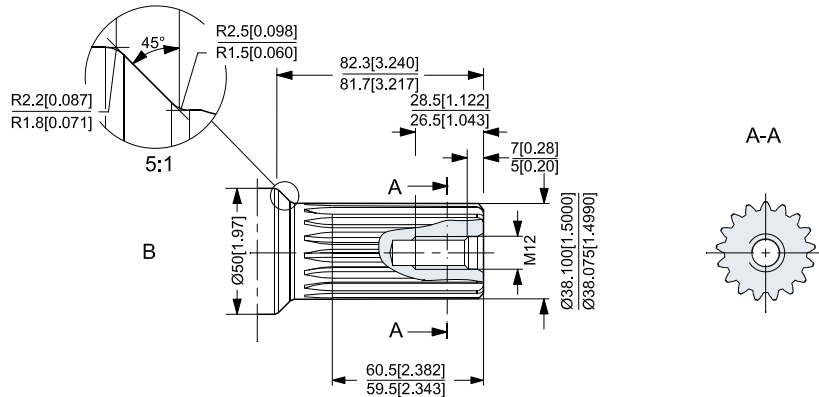

- C: Tapered shaft $\varnothing 45$ mm
 (ISO/R775)
- E: DIN 937
 Across flats: 46 mm
 Tightening torque:
 500 ± 30 N·m [4425 ± 265 lbf·in]
- D: Taper 1 : 10
- G: Parallel key
 B12 x 8 x 28

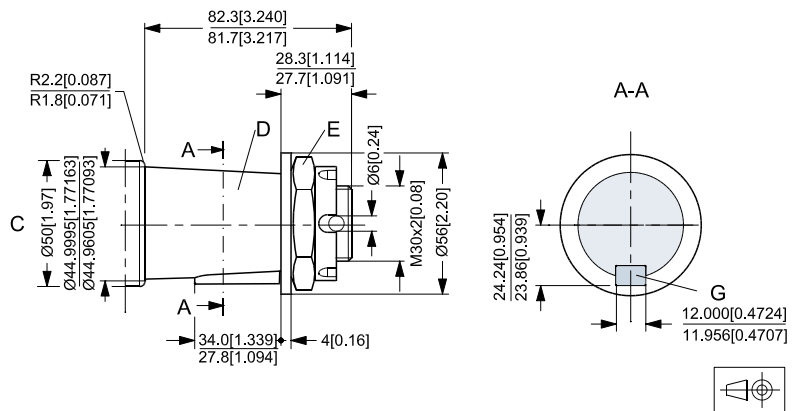

151-1806.10

Shaft Versions

- D: Cylindrical shaft
 Ø 1 1/2 inch
 I: Parallel key
 3/8 x 3/8 x 2 1/4 inch
 B.S. 46

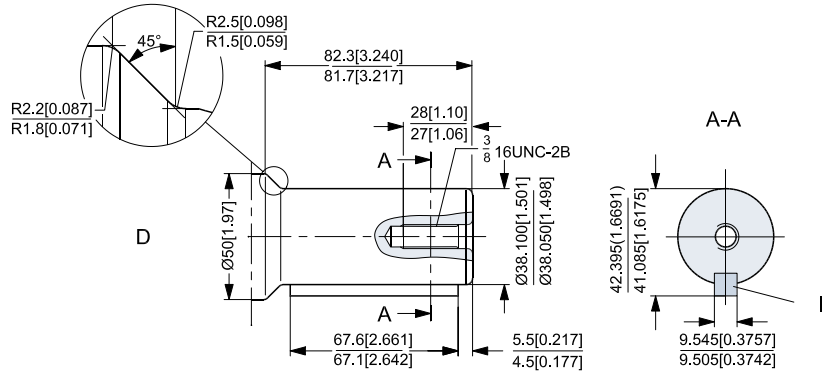

- E: Involute splined shaft ANS
 B92.1 - 1970 standard
 Flat root side fit
 Pitch 12/24
 Teeth 17
 Major diam. 1.50 inch
 Pressure angle 30°

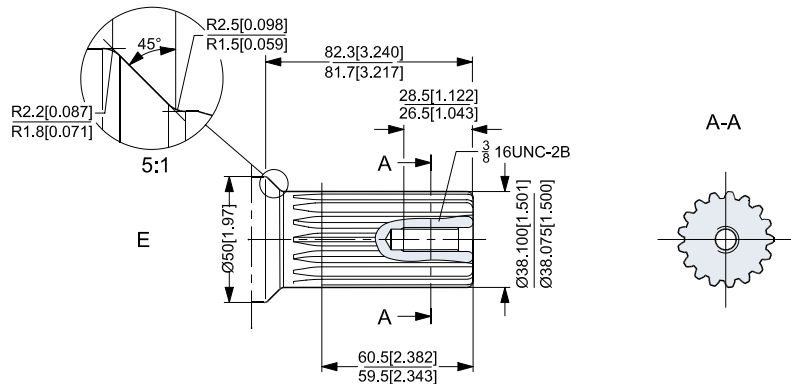

- F: Tapered shaft 1 3/4 in
 G: Cone 1 : 8
 SAE J501
 H: 1 1/4 - 18 UNEF
 across flats: 2 3/16 inch
 Tightening torque:
 4425 ± 265 lbf-in [500 ± 30 N·m]
 J: Parallel key
 7/16 x 7/16 x 1 1/4 inch
 B.S. 46

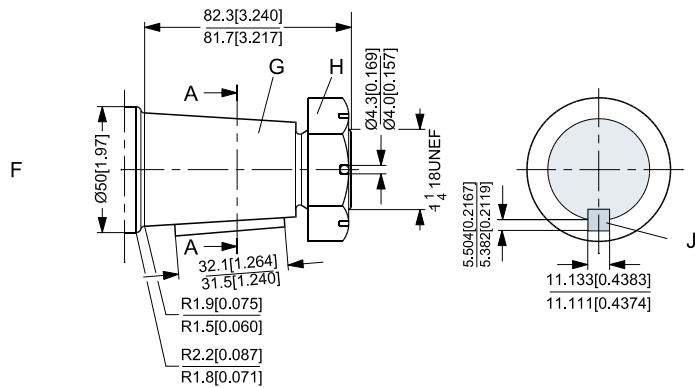

151-1921.12

Port Thread Versions

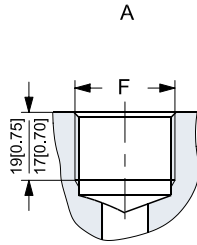

A: G Main port
 F: ISO 228/1 – G 3/4

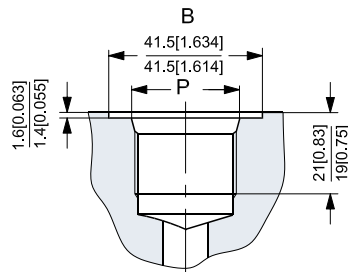

B: UNF Main port
 P: 1 1/16 – 12 UN

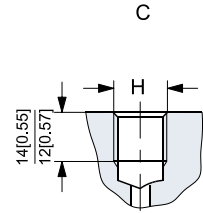

C: G Drain/release port
 H: ISO 228/1 – G 1/4

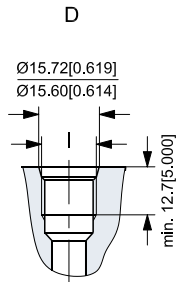

D: UNF Drain port
 I: 9/16 – 18 UNF
 O-ring boss port

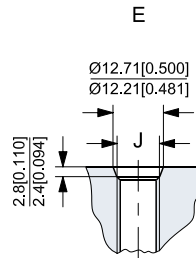

E: UNF Release port
 J: 7/16 – 20 UNF
 O-ring boss port

151-1949.10

Dimensions of the Attached Component for TMT U (bearing less)

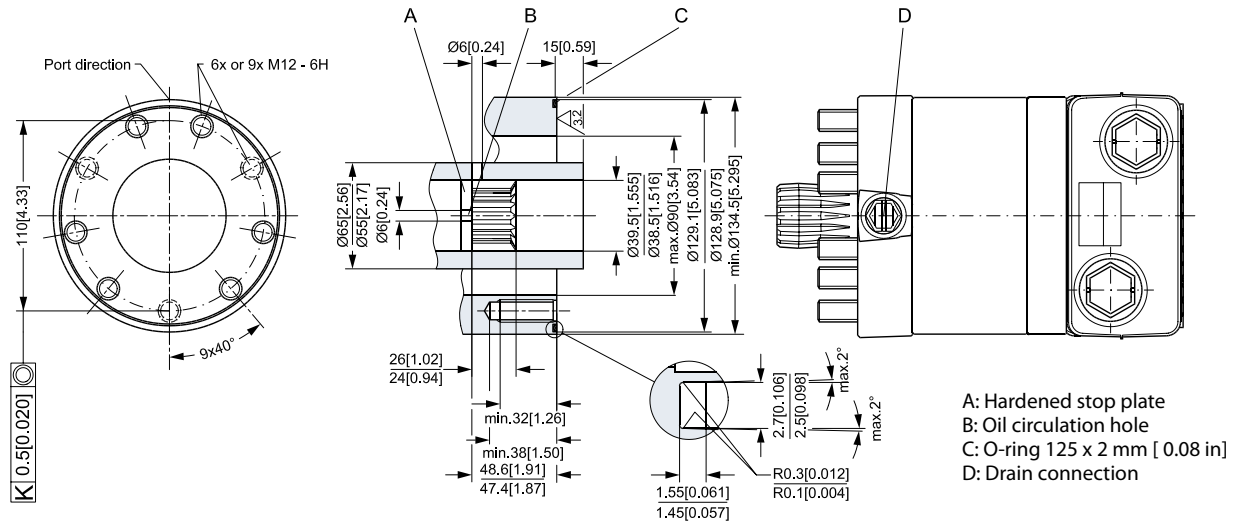

151-1920.10

Internal spline data for the component to be attached

The attached component must have internal splines corresponding to the external splines on the motor cardan shaft, please *see drawings*.

Material:

Case hardening steel with a tensile strenght corresponding at least to 20 MoCr4 (90 daN/mm²). See also SAE 8620 for further information on steel material.

Hardening specification:

- on the surface: HV = 750 ± 50
- 0.7 ± 0.2 mm under the surface: HV = 560

Standard ANS B92.1 - 1970, class 5 (corrected m . x = 1; m = 2.1166)			
Flat root side fit	mm	inch	
Number of teeth z	16	16	
Pitch DP	12/24	12/24	
Pressure angle	30°	30°	
Pitch dia.	D	33.8656	1.3333
Major dia.	D _{ri}	38.4 ^{+0.4} ₀	1.5118 ^{+0.0157} ₀
Form dia. (min)	D _{fi}	37.6	1.4803
Minor dia.	D _i	32.15 ^{+0.04} ₀	1.2657 ^{+0.00157} ₀
Space width (circular)Lo		4.516 ± 0.037	0.1777 ± 0.0014
Tooth thicknes (circulator)	S _o	2.170	0.0854
Fillet radius	R _{min.}	0.5	0.02
Max. measurement between pins*	l	26.9 ^{+0.1} ₀	1.059 ^{+0.004} ₀
Pin dia.	d	4.843 ± 0.001	0.1903 ± 0.00004

*Finished dimensions (when hardened)

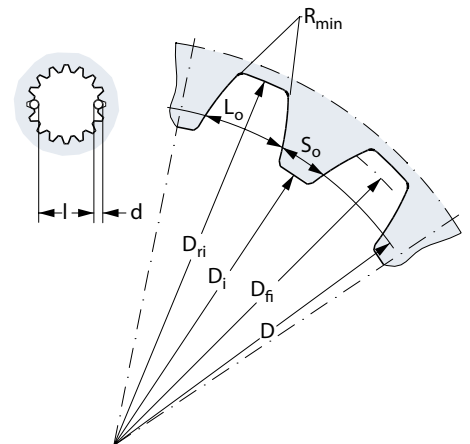

151-455.10

**Drain Connection on
TMTU or Attached
Component**

A drain line should always be used.

The drain line can be connected at two different points:

- at the motor drain connection
- at the drain connection of the attached component

If a drain is fitted to the attached component, it must be possible for oil to flow freely between motor and the attached component.

The drain line must be led to the tank in such a way that there is no risk of the motor and the attached component being drained of oil when at rest.

The maximum pressure in the drain line is limited by the attached component and its shaft seal.

Blank shaft

A blank shaft is available for TMTU motor, please contact Sauer-Danfoss Sales Organisation.

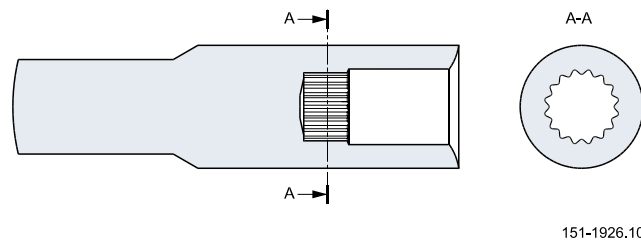

After machining the blank shaft must be hardened *according to Sauer-Danfoss specification* on page 21.

Dimensions

4-Bolt flange-spigot diameter $\varnothing 160$ mm - BC $\varnothing 200$ mm

Type	L mm [in]	L ₁ mm [in]	L ₂ mm [in]
TMT 250	191.5 [7.54]	165 [6.50]	150.5 [5.93]
TMT 315	200.8 [7.91]	174.3 [6.86]	158.9 [6.26]
TMT400	211.3 [8.32]	184.8 [7.28]	170.3 [6.70]
TMT 470	219.5 [8.64]	193 [7.60]	178.5 [7.03]
TMT 500	211.3 [8.32]	184.8 [7.28]	170.3 [6.70]
TMT 630	225.3 [8.87]	198.8 [7.83]	184.3 [7.26]

C: G ³/₄; 17 mm [0.67 in] deep
 D: Drain connection
 G ¹/₄; 12 mm [0.47 in] deep

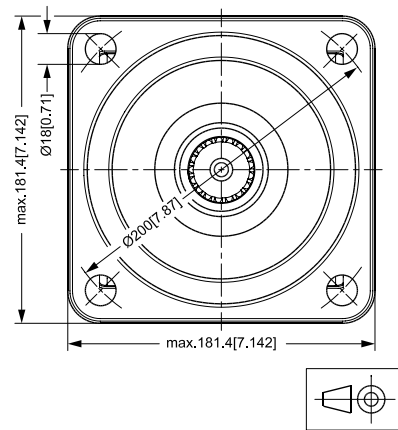
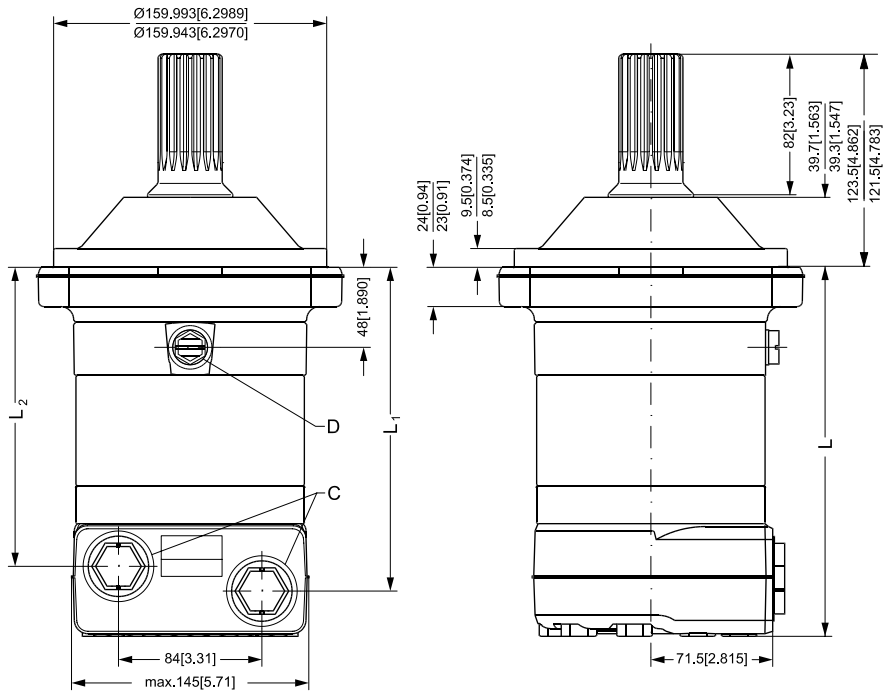

151-1804.12

Dimensions

4-Bolt flange-spigot diameter $\varnothing 125$ mm - BC $\varnothing 160$ mm

Type	L mm [in]	L ₁ mm [in]	L ₂ mm [in]
TMT 250	200 [7.87]	173.5 [6.83]	159 [6.26]
TMT 315	209.3 [8.24]	182.8 [7.20]	168.3 [6.63]
TMT400	219.8 [8.65]	193.3 [7.61]	178.8 [7.04]
TMT 470	228 [8.98]	201.5 [7.93]	187 [7.36]
TMT 500	219.8 [8.65]	193.3 [7.61]	178.8 [7.04]
TMT 630	233.8 [9.20]	207.3 [8.16]	192.8 [7.59]

- C: G 3/4; 17 mm [0.67] deep
- D: Drain connection
- G 1/4; 12 mm [0.47 in] deep

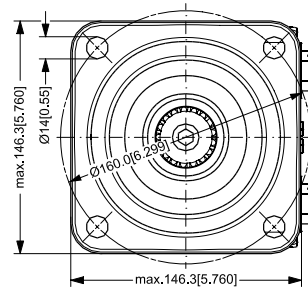
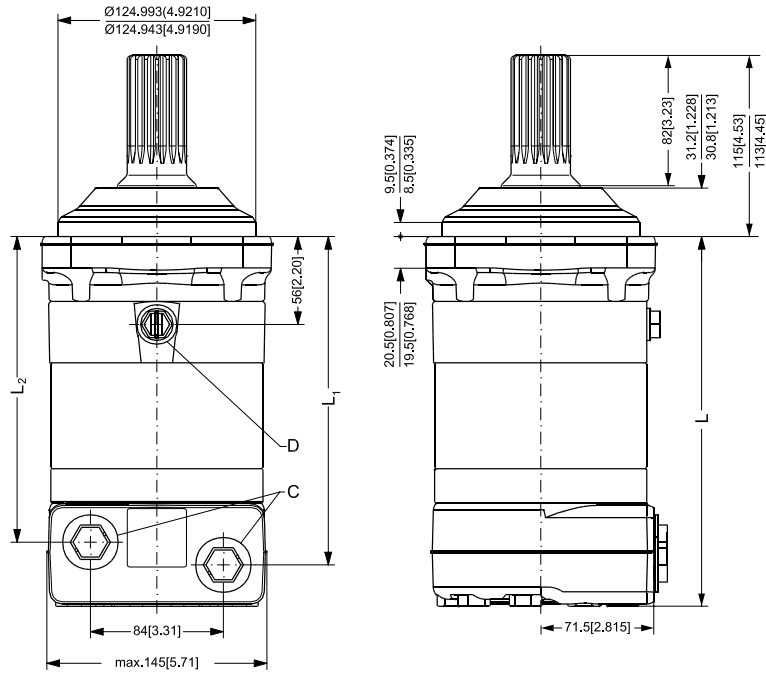

151-1929.12

Dimensions

4-Bolt flange-spigot diameter $\varnothing 5$ in, SAE C mounting flange - BC $\varnothing 6.37$ in

Type	L mm [in]	L ₁ mm [in]	L ₂ mm [in]
TMT 250	218.7 [8.61]	192.4 [7.57]	177.9 [7.00]
TMT 315	227.9 [8.97]	201.7 [7.94]	187.2 [7.37]
TMT400	238.4 [9.39]	212.2 [8.35]	197.7 [7.78]
TMT 470	246.7 [9.71]	220.4 [8.68]	205.9 [8.11]
TMT 500	238.4 [9.39]	212.2 [8.35]	197.7 [7.78]
TMT 630	252.4 [9.94]	226.2 [8.91]	211.7 [8.33]

- C: 1 $\frac{1}{16}$ -12 UN O-ring boss port;
19 mm [0.75 in] deep
- D: Drain connection $\frac{9}{16}$ -18 UNF
O-ring boss port; 12.7 mm
[0.5 in] deep

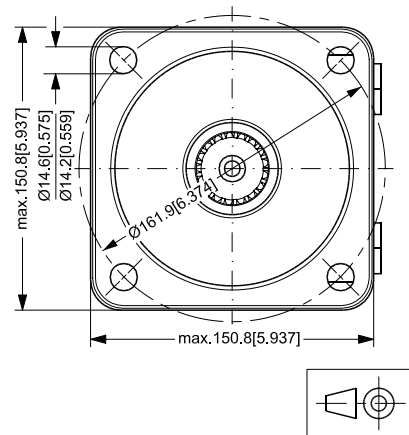
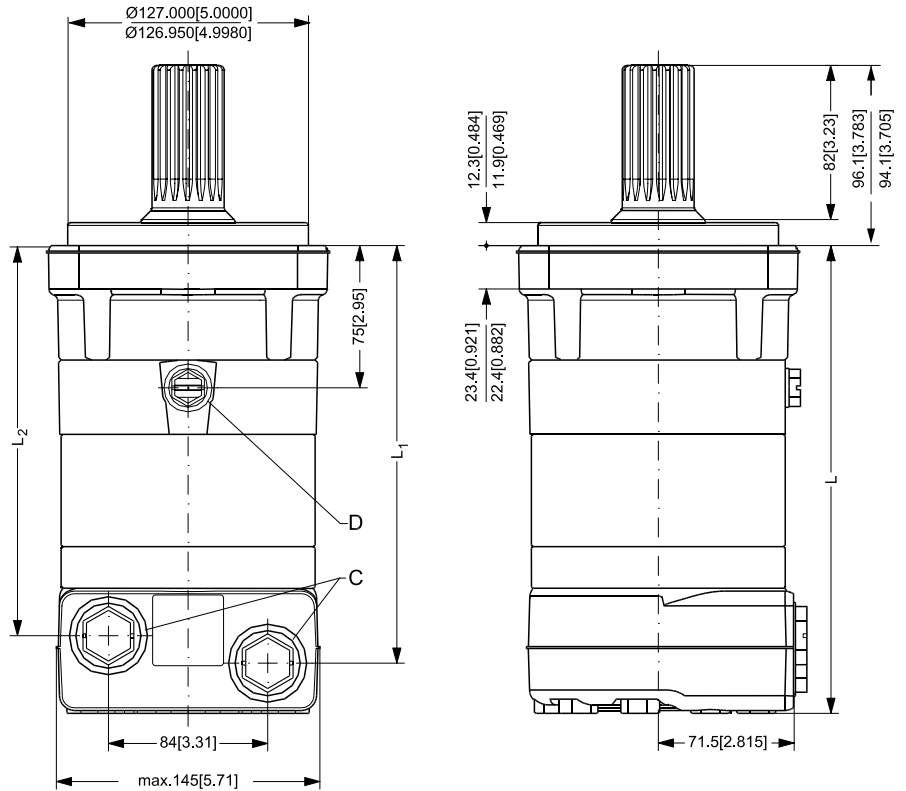

151-1932.12

Dimensions

Bearing less

Type	L mm [in]	L ₁ mm [in]	L ₂ mm [in]
TMTU 250	158.5 [6.24]	131 [5.16]	117.5 [4.63]
TMTU 315	168.8 [6.65]	141.3 [5.56]	126.8 [4.99]
TMTU 400	178.3 [7.02]	151.8 [5.98]	137.3 [5.41]
TMTU 470	186.5 [7.32]	160 [6.26]	145.5 [5.73]
TMTU 500	178.3 [7.02]	151.8 [5.98]	137.3 [5.41]
TMTU 630	192.3 [7.57]	165.8 [6.53]	151.3 [5.96]

C: G 3/4; 17 mm [0.67 in] deep
 D: Drain connection
 G 1/4; 12 mm [0.47 in] deep

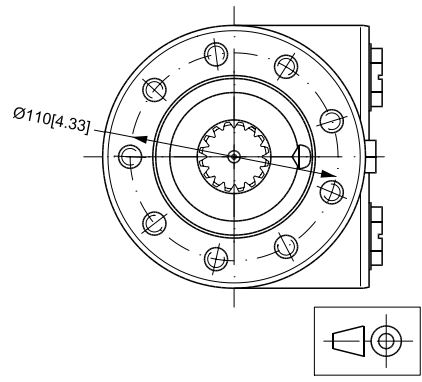
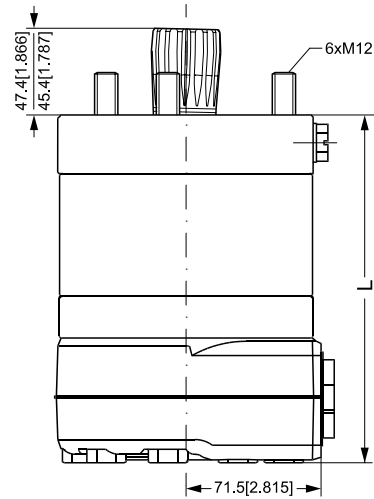
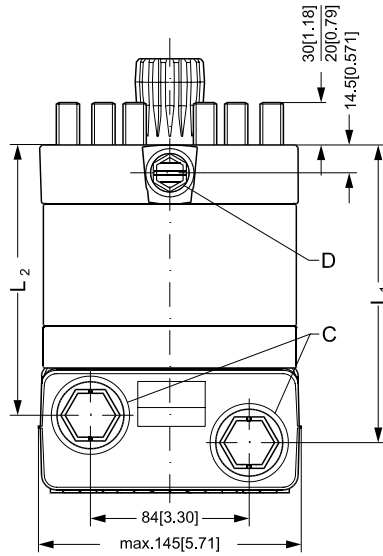

151-1800.11

Dimensions

Bearing less

Type	L mm [in]	L ₁ mm [in]	L ₂ mm [in]
TMTU 250	158.5 [6.24]	131 [5.16]	117.5 [4.63]
TMTU 315	168.8 [6.65]	141.3 [5.56]	126.8 [4.99]
TMTU 400	178.3 [7.02]	151.8 [5.98]	137.3 [5.41]
TMTU 470	186.5 [7.32]	160 [6.26]	145.5 [5.73]
TMTU 500	178.3 [7.02]	151.8 [5.98]	137.3 [5.41]
TMTU 630	192.3 [7.57]	165.8 [6.53]	151.3 [5.96]

- C: 1 1/16 - 12 UN O-ring boss port;
19 mm [0.75 in] deep
- D: Drain connection 9/16 - 18 UNF
O-ring boss port;
12.7 mm [0.5 in] deep

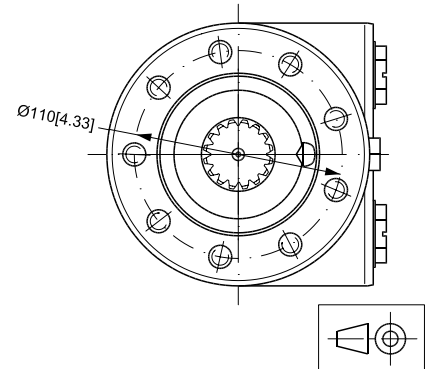
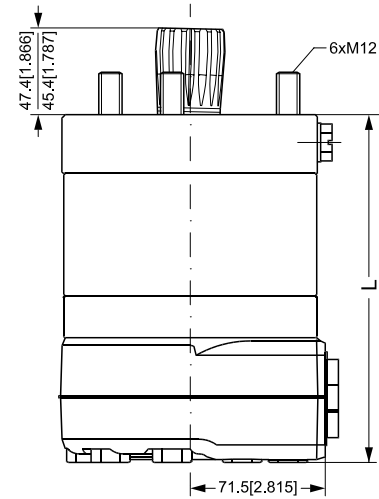
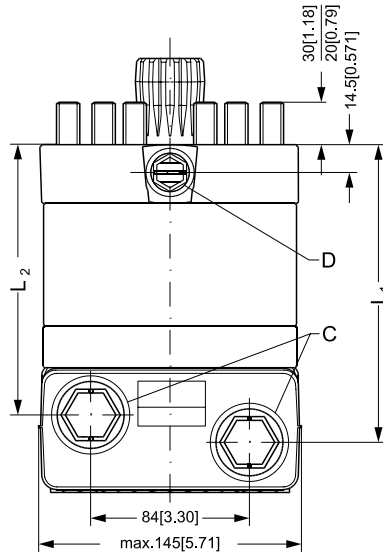

151-1800.11

Dimensions

4-Bolt flange-spigot diameter $\varnothing 125$ mm - BC $\varnothing 160$ mm

Type	L mm [in]	L ₁ mm [in]	L ₂ mm [in]
TMT 250 FL	240.1 [9.45]	213.6 [8.41]	199.1 [7.84]
TMT 315 FL	249.4 [9.82]	222.9 [8.78]	208.4 [8.20]
TMT 400 FL	259.9 [10.23]	233.4 [9.19]	218.9 [8.62]
TMT 470 FL	268.2 [10.56]	241.7 [9.52]	227.2 [8.94]
TMT 500 FL	259.9 [10.23]	233.4 [9.19]	218.9 [8.62]
TMT 630 FL	273.9 [10.78]	247.4 [9.74]	232.9 [9.17]

- C: G 3/4; 17 mm [0.67 in] deep
- D: Drain connection
G 1/4; 12 mm [0.47 in] deep
- E: Release port
G 1/4; 12 mm [0.47 in] deep

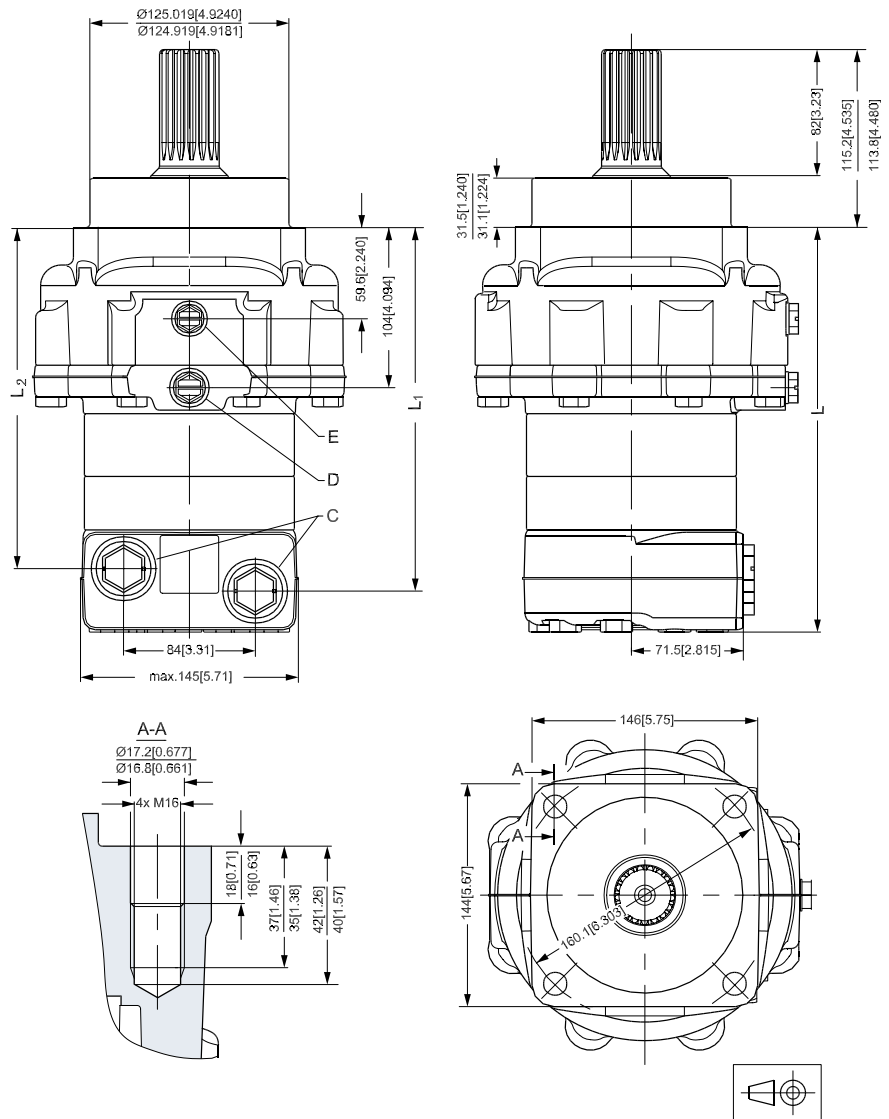

151-1941.13

Dimensions

4-Bolt flange-spigot diameter $\varnothing 5$ in, SAE C mounting flange - BC $\varnothing 6.37$ in

Type	L mm [in]	L ₁ mm [in]	L ₂ mm [in]
TMT 250 FL	259 [10.20]	232.5 [9.15]	218 [8.58]
TMT 315 FL	268.3 [10.56]	241.8 [9.52]	227.3 [8.95]
TMT 400 FL	278.8 [10.98]	252.3 [9.93]	237.8 [9.36]
TMT 470 FL	287 [11.30]	260.5 [10.26]	246 [9.69]
TMT 500 FL	278.8 [10.98]	252.3 [9.93]	237.8 [9.36]
TMT 630 FL	292.8 [11.53]	266.3 [10.48]	251.8 [9.91]

- C: 1 $\frac{1}{16}$ - 12 UN O-ring boss port;
19 mm [0.75 in] deep
- D: Drain connection $\frac{9}{16}$ - 18 UNF
O-ring boss port; 12.7 mm
[0.5 in] deep
- E: Release port $\frac{7}{16}$ - 20 UNF
O-ring boss port;
12.7 mm [0.5 in] deep

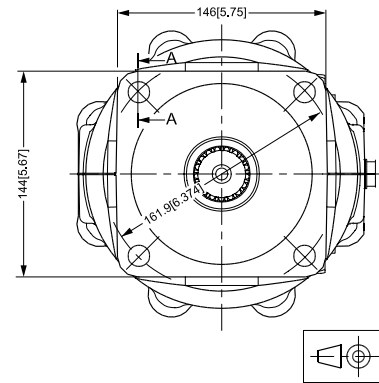
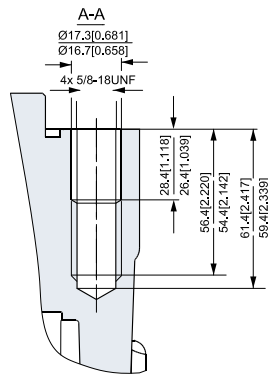
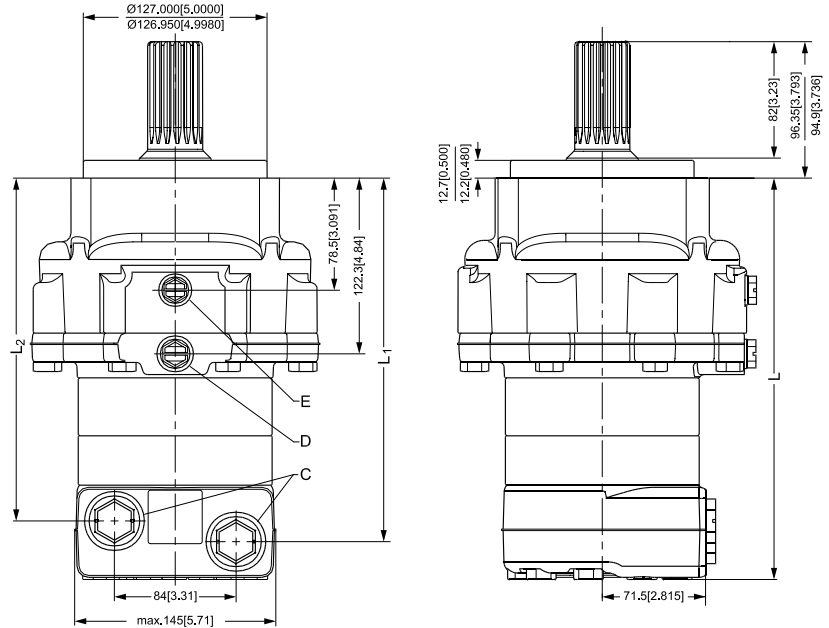

151-1941.13.22

Dimensions

4-Bolt flange-spigot diameter $\varnothing 7.08$ in - BC $\varnothing 8.82$ in

Type	L mm [in]	L ₁ mm [in]	L ₂ mm [in]
TMT 250 FL	232 [9.13]	205.5 [8.09]	191 [7.52]
TMT 315 FL	241.2 [9.50]	214.7 [8.45]	200.2 [7.88]
TMT 400 FL	251.7 [9.91]	225.2 [8.87]	210.7 [8.30]
TMT470 FL	260 [10.24]	233.5 [9.19]	219 [8.62]
TMT 500 FL	251.7 [9.91]	225.2 [8.87]	210.7 [8.30]
TMT 630 FL	265.7 [10.46]	239.2 [9.42]	224.7 [8.85]

- C: 1 $1/16$ - 12 UN O-ring boss port;
19 mm [0.75 in] deep
- D: Drain connection $9/16$ - 18 UNF
O-ring boss port; 12.7 mm
[0.5 in] deep
- E: Release port $7/16$ - 20 UNF
O-ring boss port;
12.7 mm [0.5 in] deep

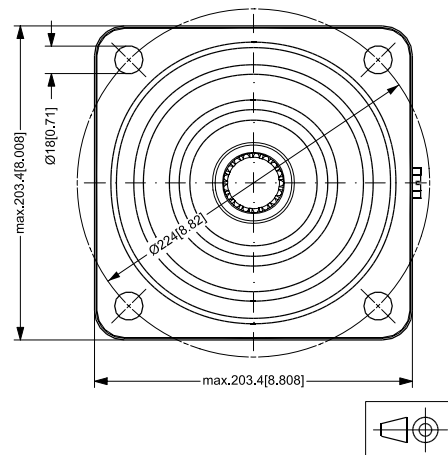
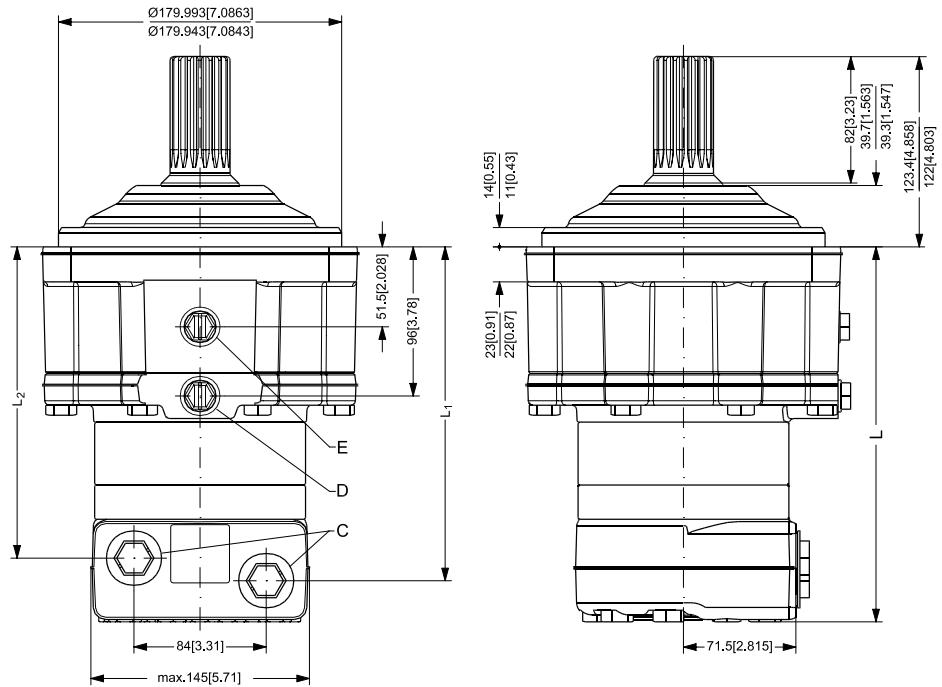

151-1928.12

Dimensions

4-Bolt flange-spigot diameter $\varnothing 180$ mm - BC $\varnothing 224$ mm

Type	L mm [in]	L ₁ mm [in]	L ₂ mm [in]
TMT 250 FL	232 [9.13]	205.5 [8.09]	191 [7.52]
TMT 315 FL	241.2 [9.50]	214.7 [8.45]	200.2 [7.88]
TMT 400 FL	251.7 [9.91]	225.2 [8.87]	210.7 [8.30]
TMT470 FL	260 [10.24]	233.5 [9.19]	219 [8.62]
TMT 500 FL	251.7 [9.91]	225.2 [8.87]	210.7 [8.30]
TMT 630 FL	265.7 [10.46]	239.2 [9.42]	224.7 [8.85]

- C: G ³/₄; 17 mm [0.67 in] deep
- D: Drain connection
G ¹/₄; 12 mm [0.47 in] deep
- E: Release port
G ¹/₄; 12 mm [0.47 in] deep

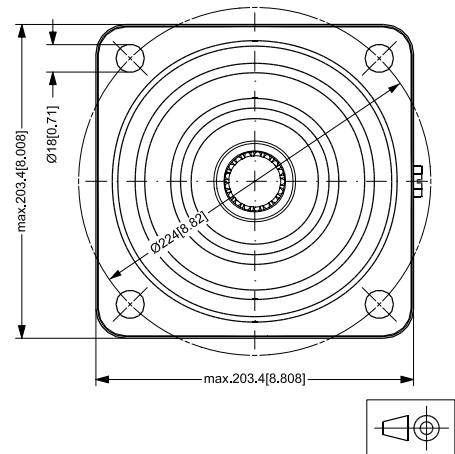
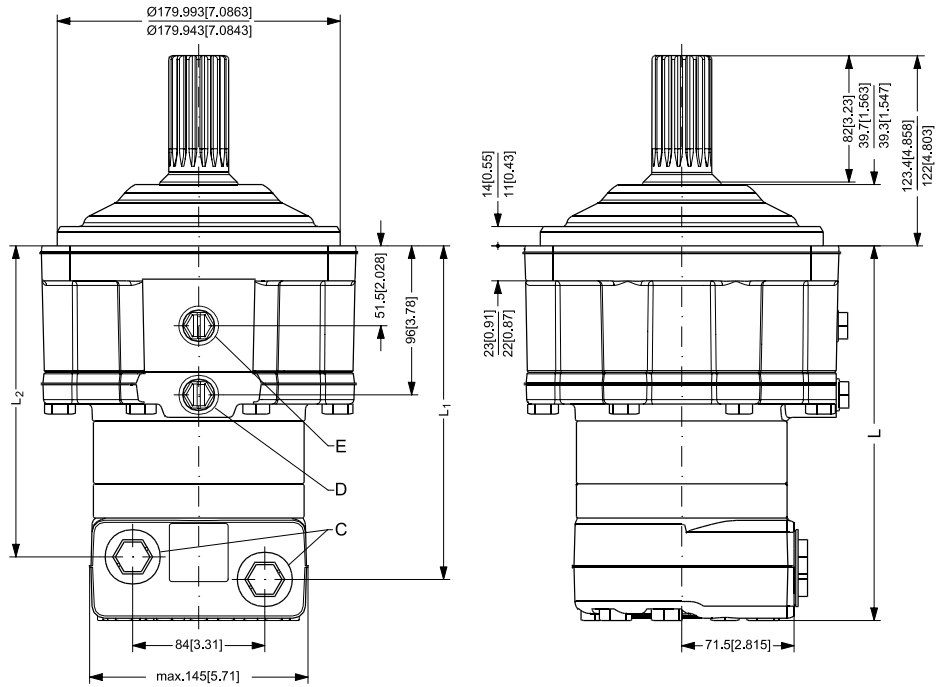

151-1928.12

Dimensions

Wheel - Spigot diameter $\varnothing 180$ mm - BC $\varnothing 210$ mm

Type	L ₁ mm [in]	L ₂ mm [in]
TMTW 250	250.1 [9.85]	99 [3.90]
TMTW 315	259.4 [10.21]	108.3 [4.26]
TMTW 400	269.9 [10.63]	118.8 [4.68]
TMTW 470	278.1 [10.95]	127 [5.00]
TMTW 500	269.9 [10.63]	118.8 [4.68]
TMTW 630	283.9 [11.18]	132.8 [5.23]

- C: G 3/4; 17 mm [0.67 in] deep
- D: Drain connection
G 1/4; 12 mm [0.47 in] deep
- E: $\varnothing 14.1$
- F: 5 x M14 • 1.5
- H: M10, 17 mm [0.67 in] deep

-----not painted

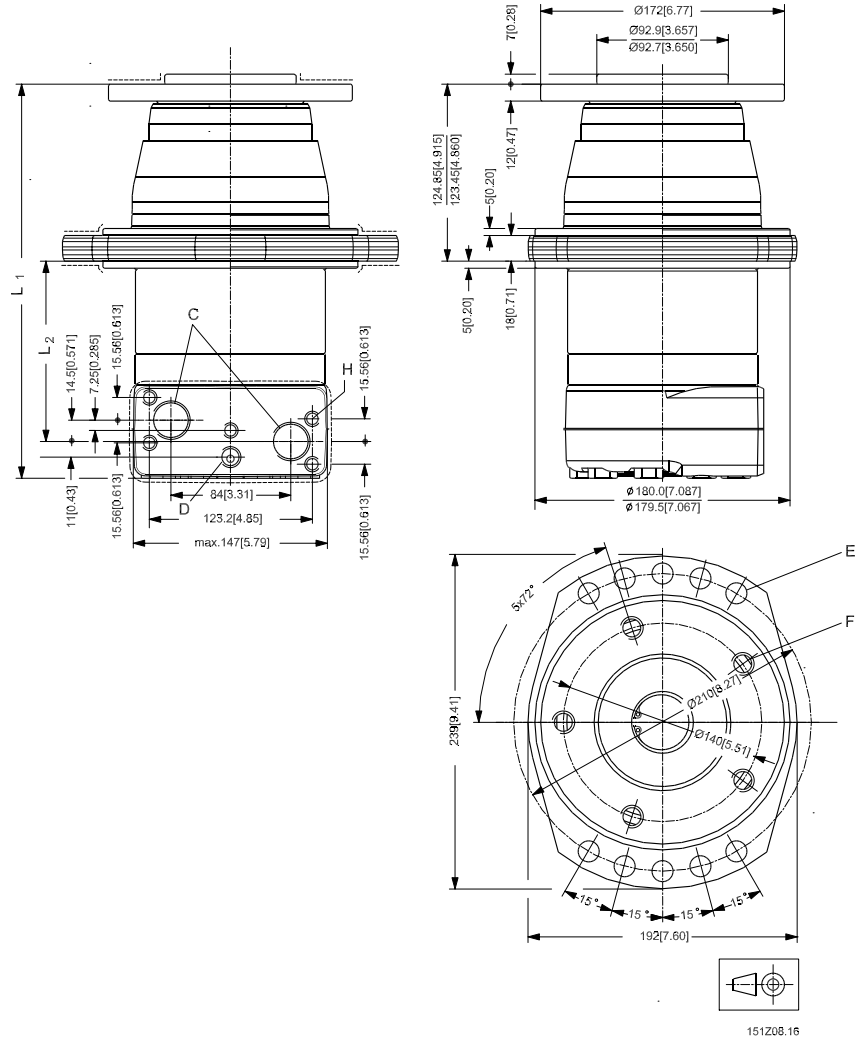

Dimensions

Wheel - Spigot diameter $\varnothing 160$ mm - BC $\varnothing 194$ mm

Type	L mm [in]	L ₁ mm [in]	L ₂ mm [in]	L ₃ mm [in]
TMTW 250 FL	131.0 [5.16]	86.8 [3.42]	101.3 [3.99]	110.8 [4.36]
TMTW 315 FL	140.2 [5.52]	96.0 [3.78]	110.5 [4.35]	120.0 [4.72]
TMTW 400 FL	150.7 [5.93]	106.5 [4.19]	121.0 [4.76]	130.5 [5.14]
TMTW 500 FL	150.7 [5.93]	106.5 [4.19]	121.0 [4.76]	130.5 [5.14]
TMTW 630 FL	164.7 [6.48]	120.5 [4.74]	135.0 [5.31]	144.5 [5.69]

- C: 1 ¹/₁₆ - 12 UN O-ring boss port; 19 mm [0.75 in] deep
- D: Drain connection ⁹/₁₆ - 18 UNF O-ring boss port; 12.7 mm [0.5 in] deep
- E: Release port; ⁷/₁₆ - 20 UNF, 13 mm [0.51 in] deep

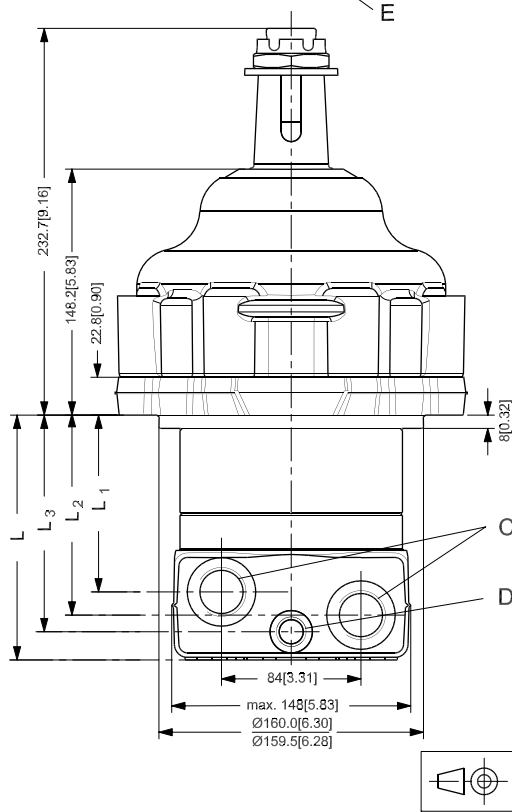
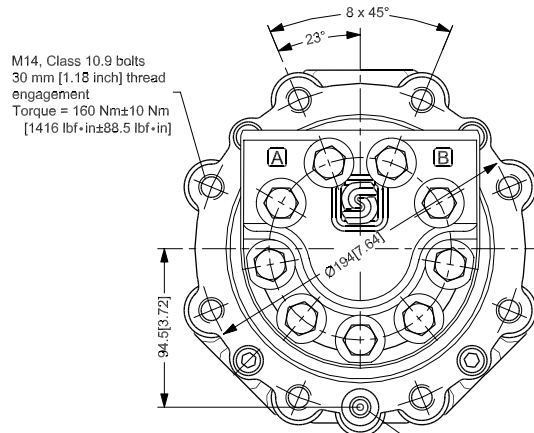

151Z43.10

Weight of Motors

Code no	Weight	
	kg	[lb]
151Z3000	16.1	[35.49]
151Z3001	16.9	[37.26]
151Z3002	17.8	[39.24]
151Z3003	18.5	[40.79]
151Z3004	19.0	[41.89]
151Z3005	19.0	[41.89]
151Z3010	25.2	[55.56]
151Z3011	26.1	[57.54]
151Z3012	27.1	[59.75]
151Z3013	27.8	[61.29]
151Z3014	28.4	[62.61]
151Z3015	28.4	[62.61]
151Z3016	22.5	[49.60]
151Z3017	23.3	[51.37]
151Z3018	24.3	[53.57]
151Z3020	25.2	[55.56]
151Z3021	26.1	[57.54]
151Z3022	27.1	[59.75]
151Z3023	27.8	[61.29]
151Z3024	28.4	[62.61]
151Z3025	28.4	[62.61]
151Z3026	22.5	[49.60]
151Z3027	23.3	[51.37]
151Z3028	24.3	[53.57]
151Z3030	25.2	[55.56]
151Z3031	26.1	[57.54]
151Z3032	27.1	[59.75]
151Z3033	27.8	[61.29]
151Z3034	28.4	[62.61]
151Z3035	28.4	[62.61]
151Z3036	22.5	[49.60]
151Z3037	23.3	[51.37]
151Z3038	24.3	[53.57]
151Z3040	35.3	[77.82]
151Z3041	36.2	[79.81]
151Z3042	37.2	[82.01]
151Z3043	38.0	[83.78]

Code no	Weight	
	kg	[lb]
151Z3044	38.5	[84.88]
151Z3045	38.5	[84.88]
151Z3050	35.3	[77.82]
151Z3051	36.2	[79.81]
151Z3052	37.2	[82.01]
151Z3053	38.0	[83.78]
151Z3054	38.5	[84.88]
151Z3055	38.5	[84.88]
151Z3060	23.9	[52.69]
151Z3061	24.7	[54.45]
151Z3062	25.7	[56.66]
151Z3063	26.5	[58.42]
151Z3064	27.0	[59.52]
151Z3065	27.0	[59.52]
151Z3070	23.9	[52.69]
151Z3071	24.7	[54.43]
151Z3072	25.7	[56.66]
151Z3073	26.5	[58.42]
151Z3074	27.0	[59.52]
151Z3075	27.0	[59.52]
151Z3080	23.9	[52.69]
151Z3081	24.7	[54.45]
151Z3082	25.7	[56.66]
151Z3083	26.5	[58.42]
151Z3084	27.0	[59.52]
151Z3085	27.0	[59.52]
151Z3090	36.7	[80.91]
151Z3091	37.6	[82.89]
151Z3092	38.6	[85.10]
151Z3093	39.4	[86.86]
151Z3094	39.9	[87.96]
151Z3095	39.9	[87.96]
151Z3100	16.1	[35.49]
151Z3101	16.9	[37.26]
151Z3102	17.8	[39.24]
151Z3103	18.5	[40.79]
151Z3104	19.0	[41.89]

Code no	Weight	
	kg	[lb]
151Z3105	19.0	[41.89]
151Z3110	39.5	[87.08]
151Z3111	40.4	[89.07]
151Z3112	41.4	[91.27]
151Z3113	42.2	[93.03]
151Z3114	42.7	[94.14]
151Z3115	42.7	[94.14]
151Z3120	39.5	[87.08]
151Z3121	40.4	[89.07]
151Z3122	41.4	[91.27]
151Z3123	42.2	[93.03]
151Z3124	42.7	[94.14]
151Z3125	42.7	[94.14]
151Z3130	39.5	[87.08]
151Z3131	40.4	[89.07]
151Z3132	41.4	[91.27]
151Z3133	42.2	[93.03]
151Z3134	42.7	[94.14]
151Z3135	42.7	[94.14]
151Z3229	27.6	[60.85]
151Z3230	28.4	[62.61]
151Z3231	29.3	[64.60]
151Z3232	30.0	[66.14]
151Z3233	30.5	[67.24]
151Z3234	30.5	[67.24]
151Z3273	27.6	[60.85]
151Z3274	28.4	[62.61]
151Z3275	29.3	[64.60]
151Z3276	30.0	[66.14]
151Z3277	30.5	[67.24]
151Z3278	30.5	[67.24]
11033922	38.3	[84.44]
11033923	39.1	[86.20]
11033924	40.0	[88.18]
11033926	41.2	[90.83]
11033927	41.2	[90.83]



Products we offer:

- Bent Axis Motors
- Closed Circuit Axial Piston Pumps and Motors
- Displays
- Electrohydraulic Power Steering
- Electrohydraulics
- Hydraulic Power Steering
- Integrated Systems
- Joysticks and Control Handles
- Microcontrollers and Software
- Open Circuit Axial Piston Pumps
- Orbital Motors
- PLUS+1™ GUIDE
- Proportional Valves
- Sensors
- Steering
- Transit Mixer Drives

Members of the Sauer-Danfoss Group:

Comatrol

www.comatrol.com

Schwarz Müller-Inverter

www.schwarzmueller-inverter.com

Turolla

www.turollaocg.com

Valmova

www.valmova.com

Hydro-Gear

www.hydro-gear.com

Sauer-Danfoss-Daikin

www.sauer-danfoss-daikin.com

Sauer-Danfoss is a global manufacturer and supplier of high-quality hydraulic and electronic components. We specialize in providing state-of-the-art technology and solutions that excel in the harsh operating conditions of the mobile off-highway market. Building on our extensive applications expertise, we work closely with our customers to ensure exceptional performance for a broad range of off-highway vehicles.

We help OEMs around the world speed up system development, reduce costs and bring vehicles to market faster.

Sauer-Danfoss – Your Strongest Partner in Mobile Hydraulics.

Go to www.sauer-danfoss.com for further product information.

Wherever off-highway vehicles are at work, so is Sauer-Danfoss.

We offer expert worldwide support for our customers, ensuring the best possible solutions for outstanding performance. And with an extensive network of Global Service Partners, we also provide comprehensive global service for all of our components.

Please contact the Sauer-Danfoss representative nearest you.

Local address:

Sauer-Danfoss (US) Company
2800 East 13th Street
Ames, IA 50010, USA
Phone: +1 515 239 6000
Fax: +1 515 239 6618

Sauer-Danfoss ApS
DK-6430 Nordborg, Denmark
Phone: +45 7488 4444
Fax: +45 7488 4400

Sauer-Danfoss GmbH & Co. OHG
Postfach 2460, D-24531 Neumünster
Krokamp 35, D-24539 Neumünster, Germany
Phone: +49 4321 871 0
Fax: +49 4321 871 122

Sauer-Danfoss-Daikin LTD.
Shin-Osaka TERASAKI 3rd Bldg. 6F
1-5-28 Nishimiyahara, Yodogawa-ku
Osaka 532-0004, Japan
Phone: +81 6 6395 6066
Fax: +81 6 6395 8585